

Model: AD-330 - STAND-BY RANGE

400/230 V - THREE-PHASE | 1.500 R.P.M. | 50 Hz

Automatic with amf/ats panel Stand-by Genset V2.

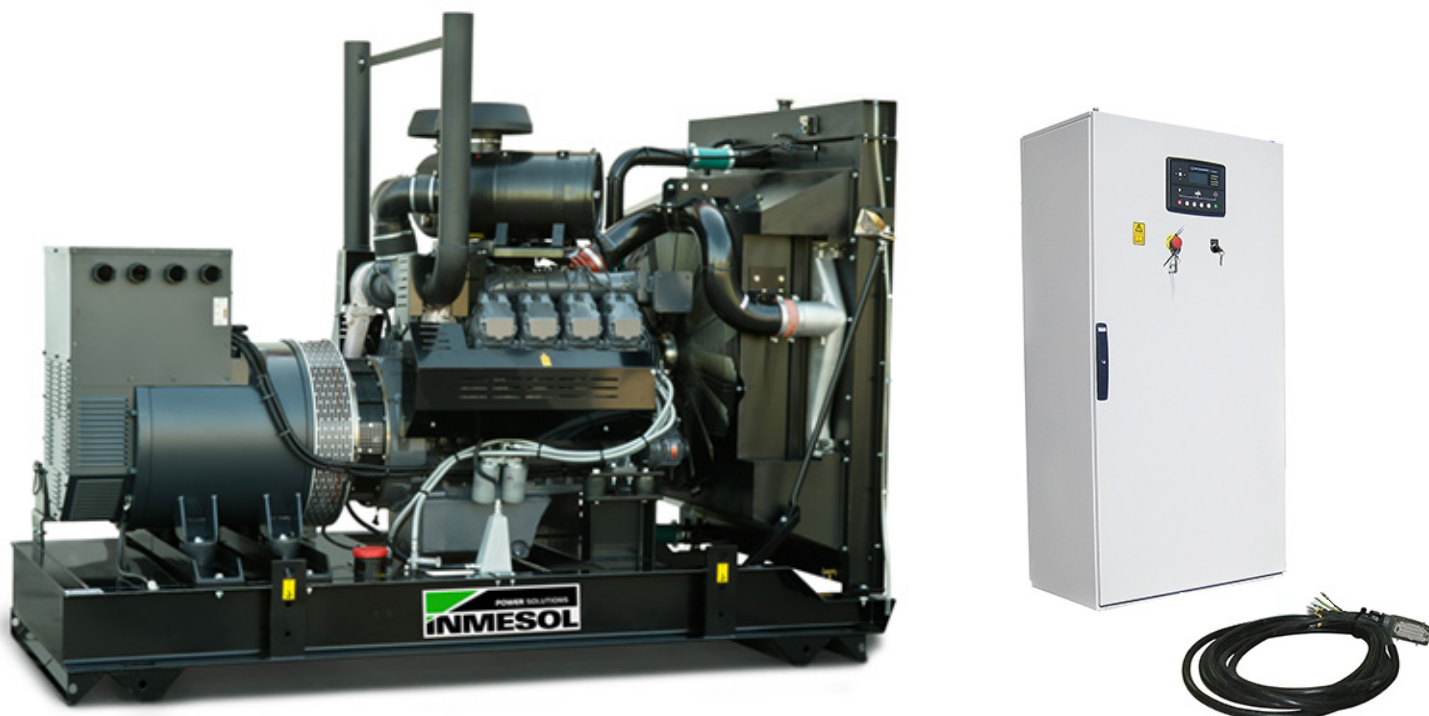

Image for guidance purposes.

PRP

CONTINUOUS POWER: 300 kVA

PRP "Prime Power" norma ISO 8528-1

LTP

STAND-BY POWER: 330 kVA

LTP "Limited Time Power" norma ISO 8528-1

ENGINE

| MAKE | MODEL |
|-------|-------------|
| DEUTZ | BF6M 1015 C |

ALTERNATOR

| MAKE | MODEL |
|-----------|------------|
| MECC-ALTE | ECO 38-2LN |

| VOLTAGE | HZ | PHASE | COS Ø | PRP kVA/kW | LTP kVA/kW | AMP. (LTP) |
|---------|----|-------|-------|-------------|-------------|------------|
| 400/230 | 50 | 3 | 0,8 | 300,0/240,0 | 330,0/264,0 | 476,88 |

ELECTRO EXIM SRL

ELECTRO EXIM SRL
21 Ialomicioarei St., sector 1, code 011277, BUCHAREST - ROMANIA
Phone: 0040 21 2231347 - 0040 744 755 390 - FAX: 0040 21 2231201
E-mail: office@electroexim.com - Web: www.electroexim.ro

Model: AD-330 - STAND-BY RANGE

400/230 V - THREE-PHASE | 1.500 R.P.M. | 50 Hz

ENGINE CHARACTERISTICS

| MAKE | MODEL |
|-------|-------------|
| DEUTZ | BF6M 1015 C |

General Data

| | |
|--------------------------|------------|
| Power PRP (kWm) | 271.20 |
| Power LTP (kWm) | 300.20 |
| No. cylinders | 6 |
| Cylinder capacity (L) | 4.76 |
| Diameter per stroke (mm) | 132 x 145 |
| Compression ratio | 16.50 |
| Cooling system | LIQUID |
| Injection | DIRECT |
| Suction | TURBO |
| Series regulator | ELECTRONIC |
| Fly wheel coupling | 1 - 14" |

Lubrication system

| | |
|-------------------------------|------|
| Oil capacity (L) | 34 |
| Oil consumption (%) | 0.30 |
| Min. alarm oil pressure (bar) | 3 |

Ventilation system

| | |
|---|-------|
| Air cooling flow (m ³ /h) | 20952 |
| Combustion air flow (m ³ /h) | 1460 |
| Max. back pressure for fan (mbar) | 0 |

Exhaust system

| | |
|--------------------------------------|------|
| Exhaust gas flow (m ³ /h) | 3995 |
| Exhaust back pressure (mbar) | 50 |
| Temp. exhaust gases (°C) | 510 |

Electrical system

| | |
|----------------------|---------|
| VDC (V) | 24 |
| Battery (Ah) | 2 x 180 |
| Engine start-up (kW) | 5.40 |

Model: AD-330 - STAND-BY RANGE

400/230 V - THREE-PHASE | 1.500 R.P.M. | 50 Hz

ALTERNATOR CHARACTERISTICS

| MAKE | MODEL |
|-----------|------------|
| MECC-ALTE | ECO 38-2LN |

General Data

| | |
|-----------------------|-------|
| Power PRP (kVA) | 300 |
| Power LTP (kVA) | 330 |
| Efficiency Alt. 3/4 % | 94 |
| Efficiency Alt. 4/4 % | 93.70 |
| No. Poles | 4 |
| Voltage regulator | DSR |
| No. wires | 12 |
| Insulation | H |
| Xd (%) | 208 |
| X'd (%) | 14.00 |
| X | 7.20 |
| Degree of protection | IP21 |

GENERATOR SET CONSUMPTION

| % POWER USED | LITRES/HOUR |
|--------------|-------------|
| 50% | 37.90 |
| 75% | 56.90 |
| 100% | 76.60 |

DIMENSIONS, CAPACITIES, APPROXIMATE WEIGHT

| Dimensions (mm) | | |
|-----------------|-------|--------|
| LENGTH | WIDTH | HEIGHT |
| 2750 | 1515 | 2252 |

| FUEL TANK (LITRES) | WEIGHT (KG) |
|--------------------|-------------|
| 562 | - |

Model: AD-330 - STAND-BY RANGE

400/230 V - THREE-PHASE | 1.500 R.P.M. | 50 Hz



INMESOL GENERATOR SET

GENERAL DESCRIPTION

The “INMESOL” generator set is an electrical energy generating machine which is used in places where there is **no mains supply** or when there is a MAINS failure.

The mobile elements, distribution belt, fan, etc., and those parts which reach high temperatures during operation, exhaust manifold, etc, include their corresponding protections, in compliance with the requirements of the Machinery Directive **2006/42**.

REGULATIONS

The machine holds the “CE” marking, and the corresponding Declaration of Conformity is issued with each of them, in which it specifies that the machine complies with **R.D 842/2002 Low Voltage Regulations and with the European Directives:**

- 2006/42 on Safety in Machinery.
- 2006/95/CE on Electrical Safety.
- 2004/108/CE on Electromagnetic Compatibility.
- 2005/88/CE on NOISE EMISSIONS by equipment for outdoor use (for SOUNDPROOF GENERATOR SETS).

Model: AD-330 - STAND-BY RANGE

400/230 V - THREE-PHASE | 1.500 R.P.M. | 50 Hz

SB **STAND-BY**
RANGE

Scope of supply

V2 **Gensets WITH AMF/ATS PANEL and 4 Pole**
Circuit Breaker

V2



Engine/alternator monobloc directly connected and installed via silent blocks on a frame made from high tensile electro welded steel profiles that are treated with degreasing liquids and aplicated with a phosphate coat and Polyester (QUALICOAT) paint.

Fuel tank integrated in the chassis provided with fuel level jauge and fuel lines to the engine.

Engine with mechanical engine driven pusher fan.

Industrial silencer with -15 db(A) noise reduction and exhaust outlet tube.

Thermal and magnetic circuit breaker

Battery charge alternator.

Starter battery complete with cables to the engine and pole protection.

Installation prepared for earthing spike (spike not included).

Security protection for belts and moving parts as well as on electrical component.

External emergency stop push button.

Self excited and auto regulated alternator.

4 Lifting points for gen sets from 450 kVA and bigger.

Base frame prepared for trailer kit

Standard electronic speed governor on engines from 220 kVA and up.

Electric control cubicle with digital control module, automatic mains failure, manual start or remote start on signal with change over switch in the same cabinet.

Battery charger for gen set with 12VCC battery (2A).

Battery charger for gen set with 24VCC battery (5A).

Electric engine coolant preheating on gen sets with automatic mains failure controller.

Control cable of 6 m

OPTIONS

Earth fault relay

Residential silencer

V1 PREWIRED VERSION
FOR AMF

V2 GENSETS WITH AMF/ATS PANEL
AND 4 POLE CIRCUIT BREAKER

V3 GENSET WITH AMF CONTROL PANEL BUT WITHOUT ATS PANEL
AND SEPARATED ATS PANEL

ELECTRO EXIM SRL

ELECTRO EXIM SRL
21 Ialomicioarei St., sector 1, code 011277, BUCHAREST - ROMANIA
Phone: 0040 21 2231347 - 0040 744 755 390 - FAX: 0040 21 2231201
E-mail: office@electroexim.com - Web: www.electroexim.ro

Model: AD-330 - STAND-BY RANGE

400/230 V - THREE-PHASE | 1.500 R.P.M. | 50 Hz

DSE 7320 AUTOMATIC CONTROL PANEL WITH AMF/ATS PANEL

V2

PROTECTION, DISTRIBUTION AND AUTOMATIC CONTROL panel which starts the generator set when it detects a mains failure and stops it when the mains is restored with the control unit DSE 7320. It incorporates change over switch. The entire assembly is in a steel enclosure separated from the gen set.



Image for guidance purposes.

It has the following:

1. EMERGENCY STOP PUSHBUTTON

2. PROTECTIONS:

Magnetothermal switch (preheating resist.) 2P (16 A)

Protection fuses for control module

3. BATTERY CHARGER

V1 PREWIRED VERSION
FOR AMF

V2 GENSETS WITH AMF/ATS PANEL
AND 4 POLE CIRCUIT BREAKER

V3 GENSET WITH AMF CONTROL PANEL BUT WITHOUT ATS PANEL
AND SEPARATED ATS PANEL

ELECTRO EXIM SRL

ELECTRO EXIM SRL
21 Ialomicioarei St., sector 1, code 011277, BUCHAREST - ROMANIA
Phone: 0040 21 2231347 - 0040 744 755 390 - FAX: 0040 21 2231201
E-mail: office@electroexim.com - Web: www.electroexim.ro

Model: AD-330 - STAND-BY RANGE

400/230 V - THREE-PHASE | 1.500 R.P.M. | 50 Hz

DSE 7320 AUTOMATIC CONTROL PANEL WITH AMF/ATS PANEL

V2

4. DSE 7320 MKII PROTECTION CONTROL MODULE.

LCD SCREEN:

It has a digital LCD screen, which provides easy reading of the information regarding the ENGINE, ALTERNATOR, MAINS and CHARGING.

| ENGINE: | ALTERNATOR AND CHARGE: | MAINS: |
|-----------------------------|---|---|
| Coolant temperature | Voltages between phases and between phases and neutral. | Frequency |
| Oil pressure | Intensities | Phase rotation order |
| Turning speed (rpm) | Frequency | Voltages between phases and neutral (L1-N, L2-N, L3-N). |
| Fuel level | Active Power (kW) | Voltages between phases and (L1-L2, L2-L3, L1-L3). |
| Battery voltage | Reactive Power (kVA) | Earth current |
| Battery alternator voltage. | Apparent Power (kVA) | |
| Operating hours | Cos phi | |
| Number of start-ups | Active energy meter (kW-h) | |

CONTROL OF THE SET:

STARTS and STOPS the set AUTOMATICALLY when mains failure is detected and when it is restored, respectively.

It can also operate MANUALLY.

PROTECTION OF THE ENGINE AND ALTERNATOR, WITH THE ALARMS ACTIVATED:

| ENGINE: | ALTERNATOR: | MAINS: |
|---|---|------------------------|
| Low oil pressure | Low and High Voltage | Low and High Voltage |
| High coolant temperature | Low and High Frequency | Low and High Frequency |
| Low and High battery Voltage. | Overload due to Intensity (A) | |
| Failure of the alternator to charge batteries | Short-circuit | |
| Low fuel level | Negative Phase Sequence. | |
| | Power Overload (KW-kVA) | |
| | Load control: | |
| | Connection and disconnection of artificial loads. | |
| | Disconnection of non-essential loads | |

OTHER CHARACTERISTICS:

| | | |
|---|--|---|
| The real-time clock provides an exact record of events. | Fully configurable via software and PC. | Programmer Clock with multiple maintenance events which can be configured for the optimal operation of the engine. Weekly and/or monthly programming of up to 16 starts and stops per week. |
| Extensive number of configurable inputs and outputs. | Modbus RTU | ALTERNATIVE CONFIGURATIONS, which open up the working possibilities |
| Configurable alarms and timers. | Possibility of SMS text messages | |
| USB connectivity | Communications Ethernet, RS 232 and RS 485 | |

V1 PREWIRED VERSION FOR AMF

V2 GENSETS WITH AMF/ATS PANEL AND 4 POLE CIRCUIT BREAKER

V3 GENSET WITH AMF CONTROL PANEL BUT WITHOUT ATS PANEL AND SEPARATED ATS PANEL

ELECTRO EXIM SRL

ELECTRO EXIM SRL
21 Ialomicioarei St., sector 1, code 011277, BUCHAREST - ROMANIA
Phone: 0040 21 2231347 - 0040 744 755 390 - FAX: 0040 21 2231201
E-mail: office@electroexim.com - Web: www.electroexim.ro

Model: AD-330 - STAND-BY RANGE

400/230 V - THREE-PHASE | 1.500 R.P.M. | 50 Hz

DSE 7320 AUTOMATIC CONTROL PANEL WITH AMF/ATS PANEL

V2

5. PROTECTIONS

| MAGNETO. PROTECTION (A) | EARTH LEAK PROTECTION | DISTRIBUTION | AMF/ATS PANEL |
|-------------------------|-----------------------|-----------------------------|---------------|
| 630A, 4P | Opcional | Direct from circuit breaker | 630 |

V1 PREWIRED VERSION FOR AMF

V2 GENSETS WITH AMF/ATS PANEL AND 4 POLE CIRCUIT BREAKER

V3 GENSET WITH AMF CONTROL PANEL BUT WITHOUT ATS PANEL AND SEPARATED ATS PANEL

ELECTRO EXIM SRL

ELECTRO EXIM SRL
21 Ialomicioarei St., sector 1, code 011277, BUCHAREST - ROMANIA
Phone: 0040 21 2231347 - 0040 744 755 390 - FAX: 0040 21 2231201
E-mail: office@electroexim.com - Web: www.electroexim.ro

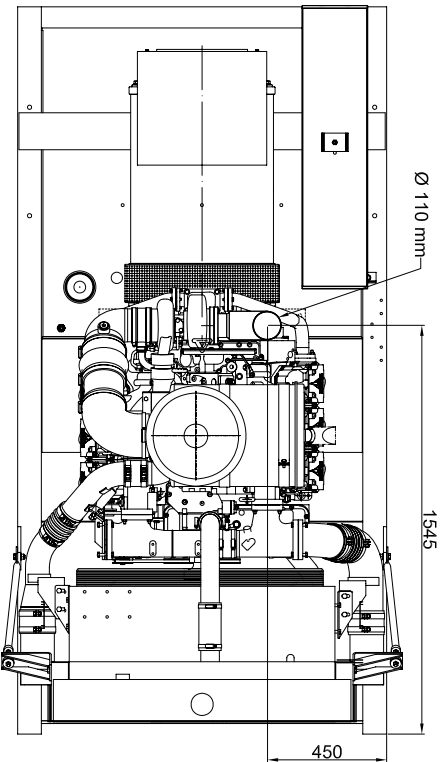
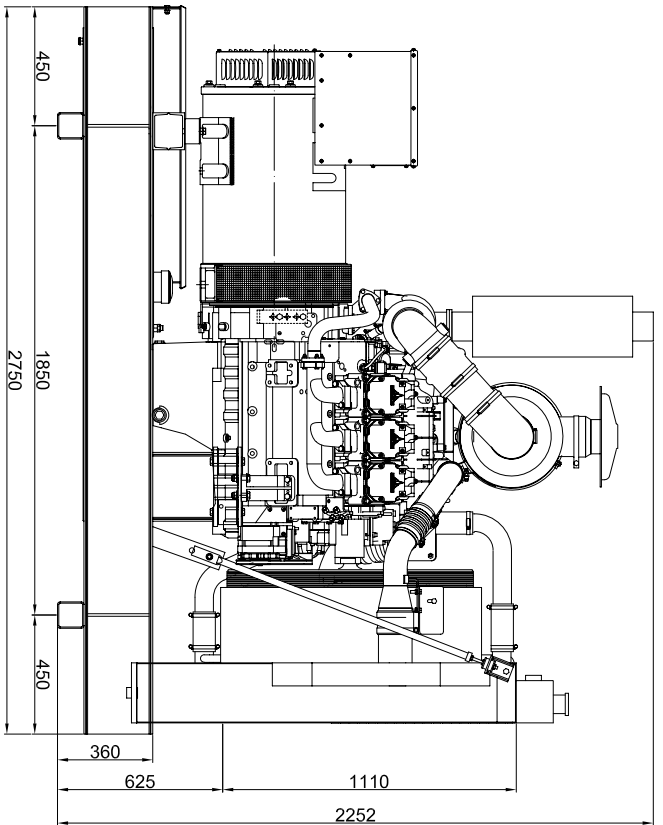
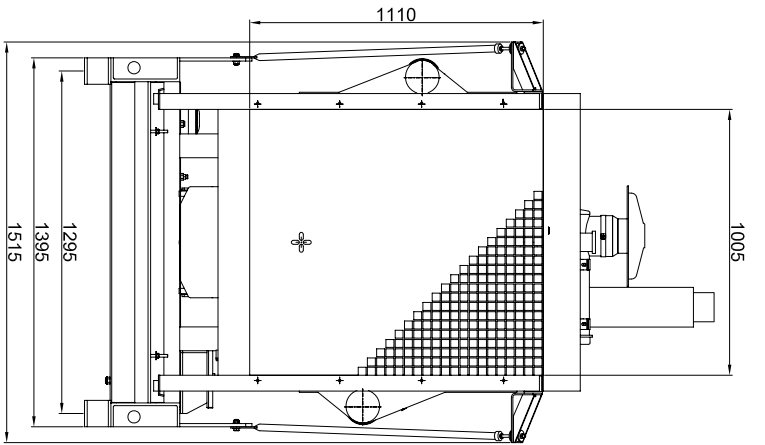

CAPACIDAD DE DEPOSITO = 562 LTS

| | | | |
|---|-----------------------------------|--|--------------------|
|  | | <p>Las tolerancias o surtos de agua de origen, a de fabrica, se especifican en el manual de instrucciones. La capacidad de almacenamiento de agua en el depósito depende de la altura de llenado y de la presión de llenado. La capacidad de almacenamiento de agua depende de la altura de llenado y de la presión de llenado. La capacidad de almacenamiento de agua depende de la altura de llenado y de la presión de llenado.</p> | |
| PROYECTO: | G.E. EST-STD 312 Kva DEUTZ (AGUA) | | |
| MODIFICADO | JASBEAR | 12-Ago-2011 | TOLERANCIA GENERAL |
| COMPROBADO | AL-SOULANI | 12-Ago-2011 | UDS |
| DENOMINACION: | G.E. EST-STD 312 Kva DEUTZ | | |
| ESCALA | DIMENSIONES GENERALES | | |
| ESCALA | MATERIAL | | |
| ESCALA | TOLERANCIA GENERAL | | |
| ESCALA | UDS | | |
| ESCALA | EXPEDIENTE: | | |
| ESCALA | Nº PLANO | | |
| ESCALA | MARCA | | |

